



COSMODYNE

A Cryogenic Industries Company

ELM SERIES

NITROGEN LIQUIFIERS

The ELM series plants produce liquid nitrogen. Production ranges from 100 to 9000 Nm³/hr. Built to high standards of reliability and efficiency, the ELM plant uses surplus nitrogen from an existing plant and liquefies the Nitrogen.

Process Description—The ELM Liquefier produces sub-cooled liquid nitrogen from a nitrogen feed gas supply. It utilizes a medium pressure refrigeration cycle in which Nitrogen is compressed above the critical pressure and then expanded through turboexpanders. The unit is equipped with single or dual turboexpanders (> 500 Nm³/hr) for more efficient production.

Quality— The ELM series plants are designed and constructed to Cosmodyne’s high quality standards. The vessels are designed and built to Section VIII, Div. 1 of the ASME Boiler and

Pressure Vessel Code and carry the Code stamp and nameplate—The electrical system is designed and constructed in accordance with NEC or IEC standards. The piping systems are designed in accordance with ASME B31.3 (except cooling water piping). Cooling water and refrigeration piping are designed and built to current industrial standards.

Control System—The control system for the ELM series plants consists of an Allen Bradley PLC platform and an operator interface utilizing a Microsoft Windows based computer.

Performance—The expected performance of the ELM liquefier in conjunction with the existing plant, drastically reduces the overall specific power. Larger productions to match our POPLAR series air separation plants are available.

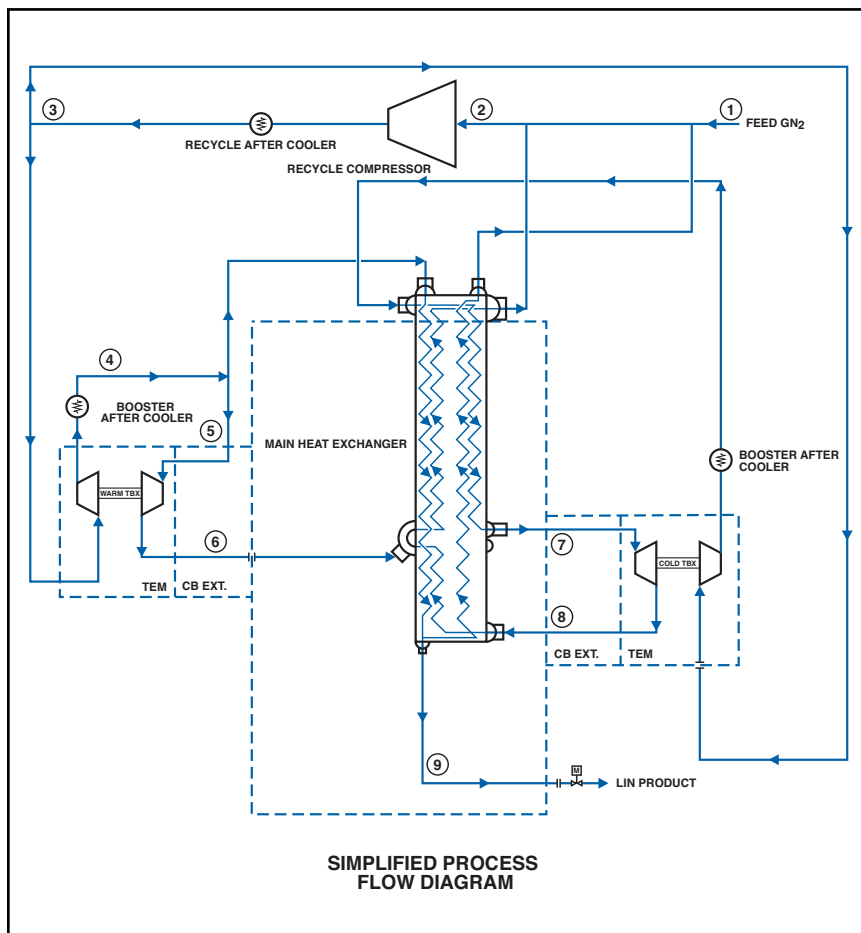

Simplified process flow diagram

(1) Nitrogen feed gas from the customer’s source is combined (2) with nitrogen gas drawn from the main heat exchanger, goes to recycle compressor (3), which feeds into two booster compressors driven by the turboexpanders (TBX). (4) The discharge from the booster compressors goes to the main heat exchanger where it is cooled. (5) A portion of this high pressure stream goes to feed the “warm TBX”. (6) It then leaves the “warm TBX” and returns to the main heat exchanger to provide part of the refrigeration. (7) After being cooled, a second diversion occurs, in which part cools the “cold TBX”, (8) then it leaves the “cold TBX” and returns to the main heat exchanger. The discharge from the “cold TBX” is cold enough to liquefy the remaining portion in the heat exchanger and (9) thus forming liquid nitrogen.

PERFORMANCE SPECIFICATIONS

ELM Performance	ELM 100	ELM 250	ELM 500	ELM 1000	ELM 3000	ELM 9000
Production -Nm ³ /hr LIN	100	250	500	1000	3000	9300
Product Purity PPM O ₂ (depends on the supply of N ₂)	5	5	5	5	5	5
Product Pressure bara	6.5	6.5	6.5	6.5	6.5	6.5
Product Temperature °K	82	82	82	82	82	82
Feed Pressure bara	5 min.	1.03 min.	1.03 min.	1.03 min.	1.03 min.	1.03 min.
Feed Temperature °C	38	38	38	38	38	38
Estimated Power kW	134	295	525	840	1,920	5,388
Specific Power kW-hr/Nm ³	1.03	1.18	1.05	0.84	0.64	0.58

Plant performance is based on standard atmospheric conditions (ambient temperature 20° C, relative humidity 50%, cooling water temperature 19° C, 1.0 atm barometric pressure)
 Specific power excludes cooling water power.

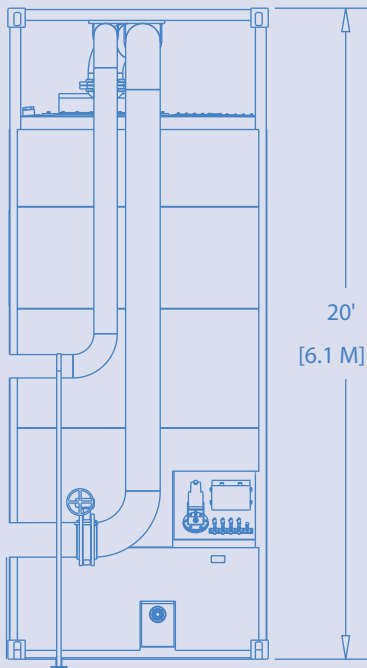

ELEVATION VIEW

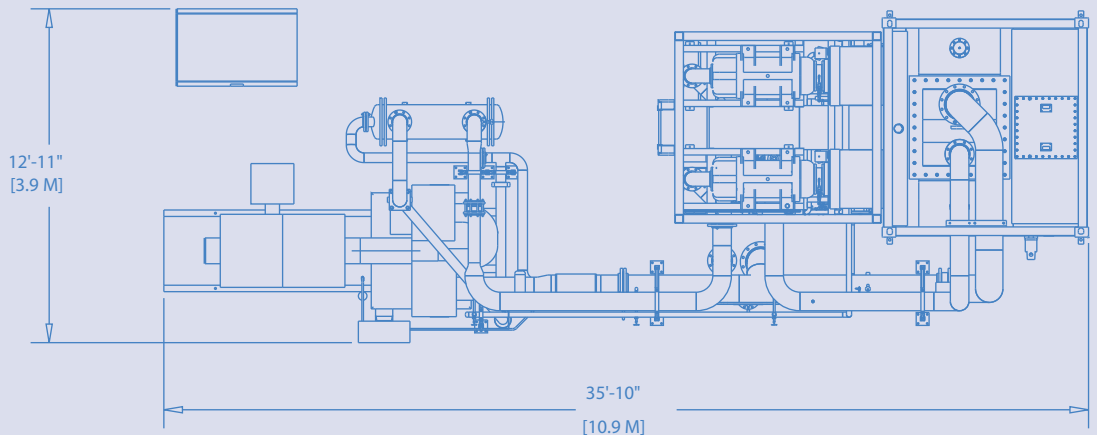
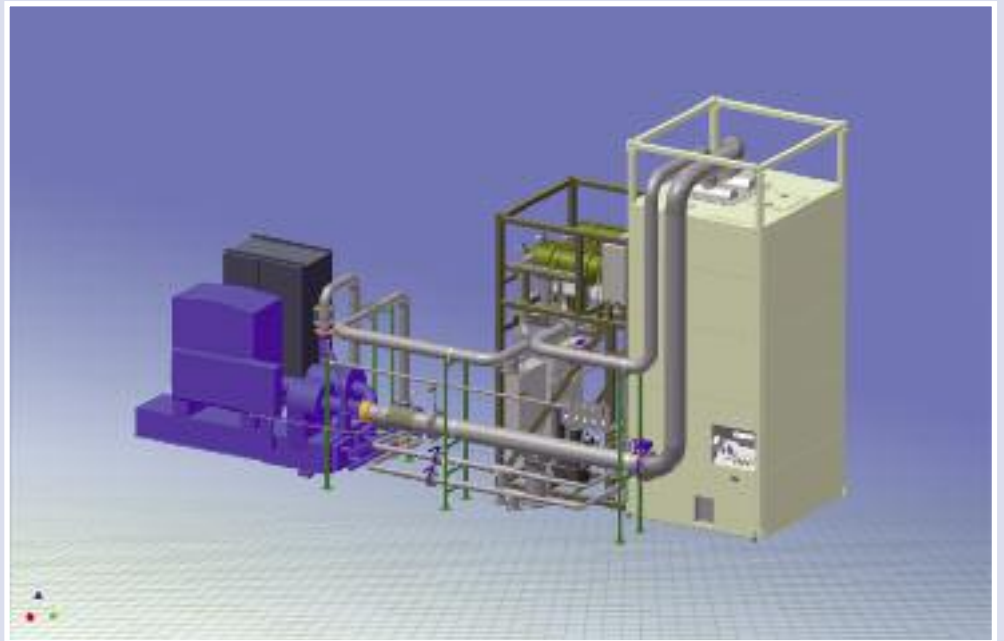

PLAN VIEW

Cosmodyne has been a world leader in the design and manufacture of modular air separation plants since 1976 with over 400 plants operating around the world.

Each Cosmodyne system is designed and built to rigorous standards of quality and workmanship developed from more than fifty years of specific experience. From initial customer contact through the manufacturing process and commissioning, and well beyond, our sales, engineering, manufacturing and field service personnel continually demonstrate our commitment to customer satisfaction. Our worldwide service network stands by ready to serve you 24 hours a day.

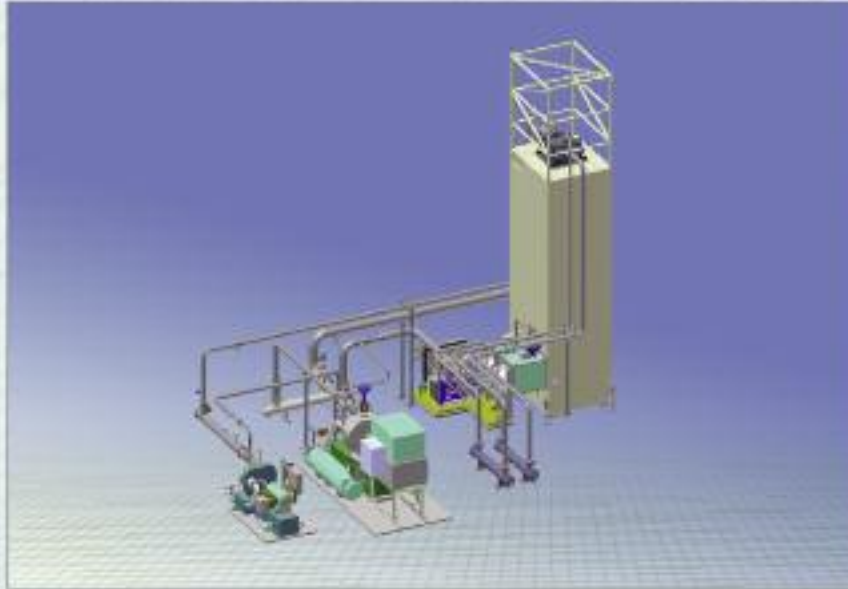

COSMODYNE, LLC • 3010 Old Ranch Parkway • Seal Beach, CA 90740 USA
• Tel: +1(562) 795-5990 • Fax: +1(562) 795-5998
E-mail: info@cosmodyne.com • www.cosmodyne.com



Other Cryogenic Industries Companies



Cryogenic Pumps and Turboexpanders
ACD, LLC
Santa Ana CA
+1 949 261 7533
<http://www.acdcom.com>

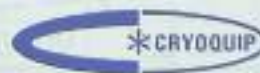

Vaporizers and Backup Systems
Cryoquip, Inc.
Murrieta, CA
+1 951 677 2060
<http://www.cryoquip.com>